



AMES
aerospace

BEYOND IMAGINATION

Welcome to AMES

As a true one-stop shop, the AMES Group delivers a comprehensive portfolio of services to the global aviation industry. Our expertise covers EASA Part 21J Design, Part 21G Production, Part 145 Maintenance, EASA Part CAMO, complemented by Consulting and Training – providing our customers a seamless and reliable partnership across the entire aircraft lifecycle.

AMES has earned a strong reputation for quality and expertise. Since obtaining **EASA Part 21J Design Organisation** Approval in 2006, our engineering team has successfully delivered more than 2,500 certification projects.

Our **EASA Part 21G Production Organisation** has developed a versatile portfolio of cabin conversion

products. Through highly efficient production and customization processes, we deliver industry-leading turnaround times without compromising quality.

With our **EASA Part 145 Maintenance Organisation**, we support the full product lifecycle, helping customers maximize long-term performance and reliability.

AMES Ireland, holding **EASA Part CAMO** approval, assists airlines and leasing companies in maintaining airworthiness, managing aircraft transitions and handling registration changes. Strategically located in Dublin, our expert CAMO and customer support teams are ideally positioned to serve the dynamic leasing market with responsiveness and expertise.

Drawing on extensive experience across the global aviation sector, we are able to deliver expert **Consulting and Training** services across a broad range of aviation disciplines.

The AMES Group is a **trusted partner** and leading provider of turnkey aviation and retrofit solutions - committed to innovation, quality, and delivering value at every stage. We look forward supporting your next project!

From left:
Michael Thaller, CEO Design Organisation
Jonathan Turner, Key Account Manager
David Tierney, COO AMES Ireland
Daniel Maier, CEO Production Organisation
Walter Starzacher, Founder & President
Michael Ziegerhofer, VP Sales & Customer Relations



Where we are



ABOUT AMES

AMES Ireland:
CAMO Engineering,
Customer Support Office



AMES Headquarter Austria:
Part21J, Part21G, Part145 and CaT
Main Offices; Production Facility

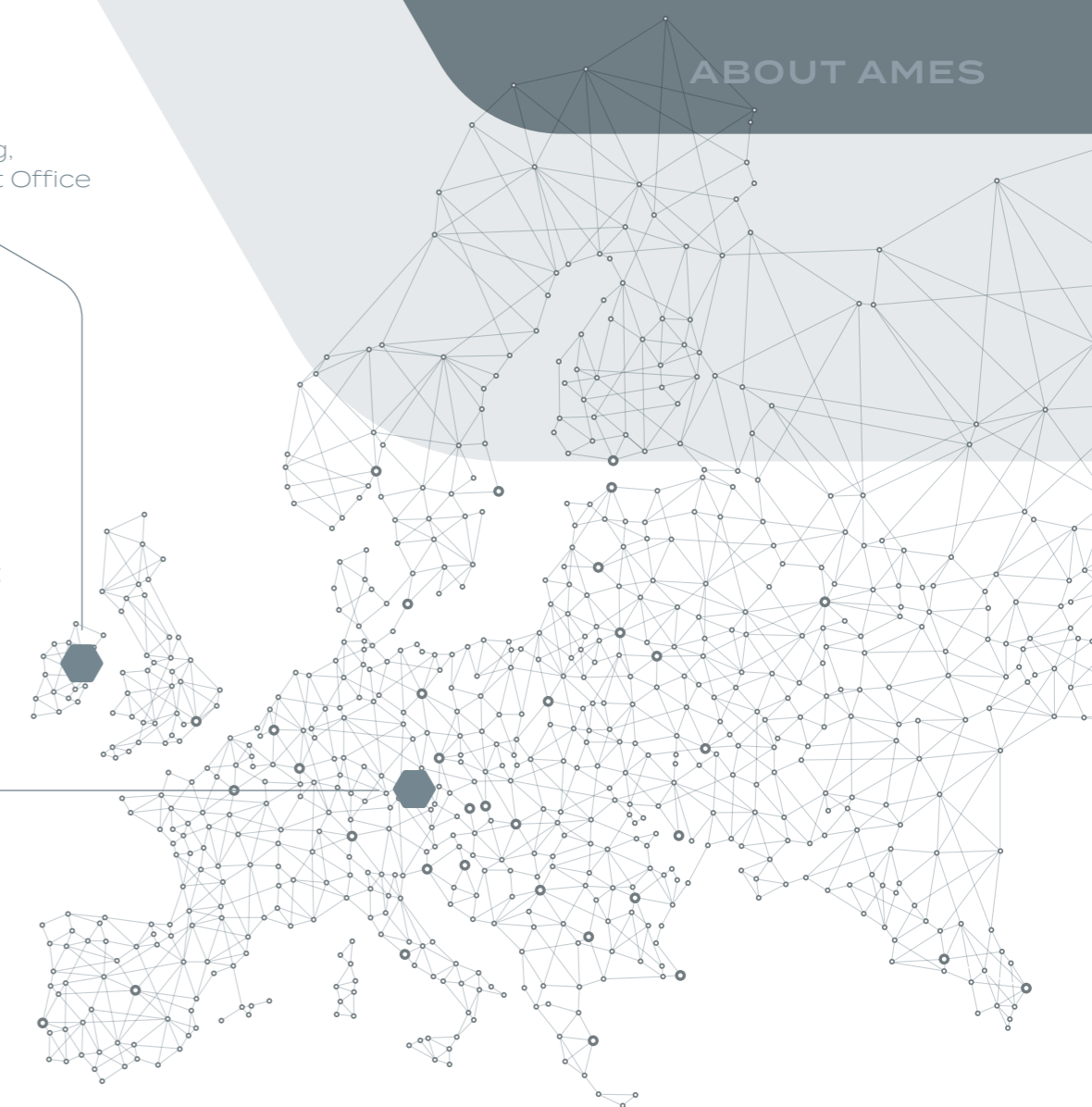

Our Services



AMES
aerospace



AMES
engineering
& certification

› EN/AS9100 certified Engineering Supplier since 2004



AMES
production
& logistics

› EASA Part21J certified Design Organisation since 2006 (EASA.21J.299)



AMES
ireland
camoservices

› EASA Part21G certified Production Organisation since 2009 (AT.21G.0015)



AMES
consulting
& training

› EASA Part145 certified Maintenance Organisation since 2015 (AT.145.082)

› EASA Part CAMO certified Continuing Airworthiness Management Organisation since 2020 (IE.CAMO.123)

› Consulting & Training Services since 2011



Engineering & Certification



Approved Engineering Service Supplier since 2004

- › Minor Changes and Supplemental Type Certificates (STCs)
- › Privilege STCs for Cabin Reconfigurations
- › Design, Qualification and Certification Services
- › Interior Components / Equipment Design and Integration
- › Cabin Modifications, Upgrades and Refurbishments
- › Electrical Systems, IFE and ISPS System Integration and Upgrades
- › Stress, Fatigue and Damage Tolerance Analysis
- › Registration Changes
- › Emergency Equipment Changes
- › Livery Changes
- › External & Internal Placard & Marking Changes

Your Turnkey Solution

- › Program Management
- › Engineering and Certification
- › Vendor Coordination
- › Hardware Production
- › Part Sourcing and Kitting
- › On-Site Installation Support

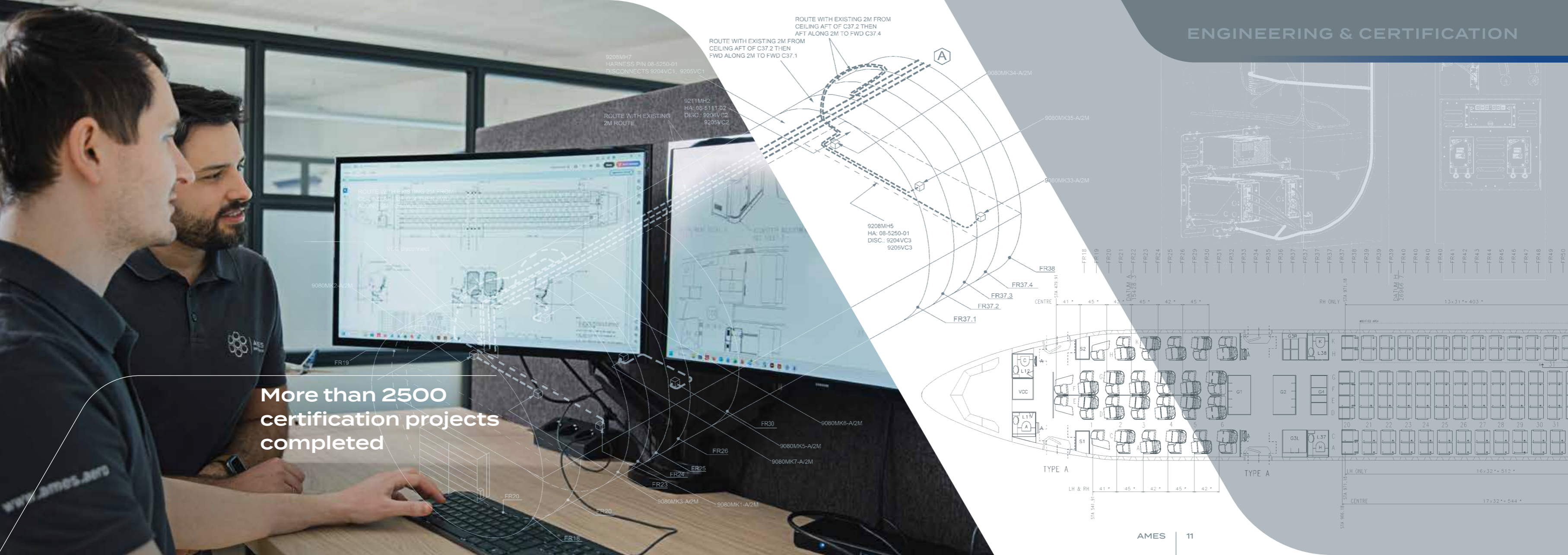

More than 2500 certification projects completed

9208MH7
HARNESS P/N 08-5250-01
DISCONNECTS 9204VC1, 9205VC1

ROUTE WITH EXISTING 2M FROM CEILING AFT OF C37.2 THEN FWD ALONG 2M TO FWD C37.1

9211MH2
HA: 08-5111-02
DISC: 9204VC2, 9205VC2

ROUTE WITH EXISTING 2M ROUTE

ROUTE WITH EXISTING 2M FROM CEILING AFT OF C37.2 THEN AFT ALONG 2M TO FWD C37.4

9208MH5
HA: 08-5250-01
DISC: 9204VC3, 9205VC3

9080MK34-A/2M

9080MK35-A/2M

9080MK33-A/2M

FR38

FR37.4

FR37.3

FR37.2

FR37.1

FR30

9080MK6-A/2M

FR26

9080MK5-A/2M

FR25

9080MK7-A/2M

FR24

FR23

9080MK3-A/2M

9080MK1-A/2M

FR20

FR20

FR18

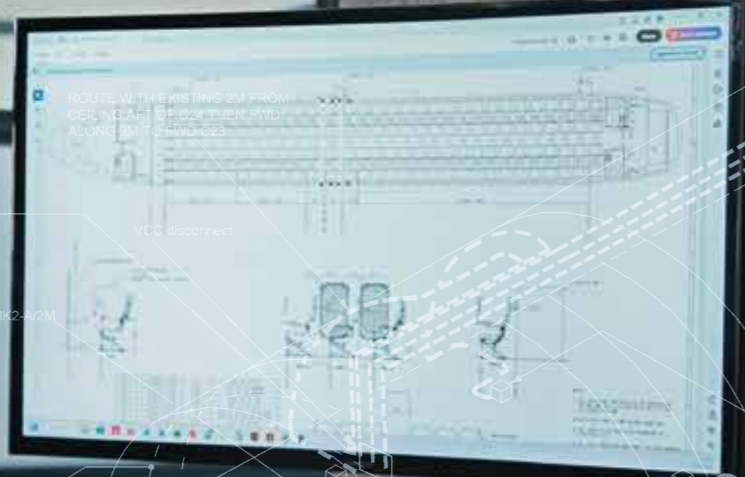



AMES STC Privilege

Your Benefits

- > Fast turnaround times
- > Schedule independent of EASA involvement
- > Cost efficiency
- > Compliance with EASA regulations

Applicable to Typical Major Cabin Modifications

- > LOPA changes with 16g seats & HIC
- > LOPA changes affecting monuments
- > LOPA changes affecting exit areas



Production & Logistics

Approved Production Services since 2009



Partitions & Windscreens



Placards and Markings

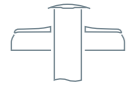

Moveable Class Dividers (MCD)



Brackets & Support Hardware



PSU Mounted Dividers



Aircraft Installation & Modification Kits



Stowages



Removable Crew Rest Units



Ancillary Equipment



**Designed to your needs,
built & certified with
shortest leadtimes
in the industry**



Customized to your Cabin

Partitions & Windscreens

Single Aisle & Wide Body

Single Aisle Partitions & Windscreens

A32F CEO & NEO with Classic / Enhanced / Airspace Interior

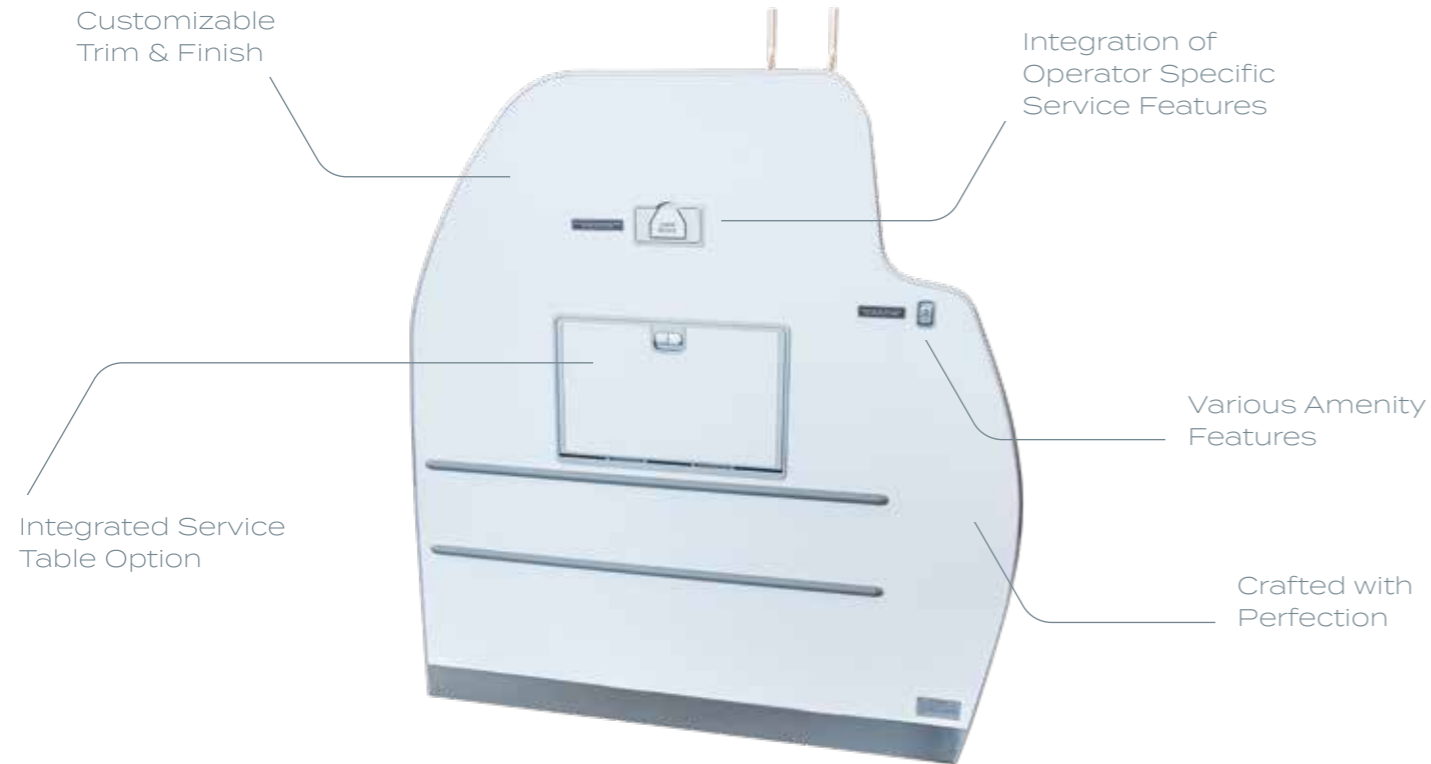

- Wide Range of T&F Options
- Integration of Customer Specific Design & Product Features
- Observer Window with Smart Glass Option
- Flush Integrated Service Table
- Baby Bassinet, Coat Hooks etc.
- Airline Logo Branding
- IFE / LCD Provisions



Single Aisle Partitions & Windscreens

B737NG & MAX with NG / Sky Interior

Underbin Class
Divider (Straight or
Z-Shape Option)



Optional Observer
Window



Half-Height
Equipment Stowage



Full-Height
Equipment Stowage



Customization
Options

- Full Height or Underbin Design
- Equipment Stowages
- Wide range of T&F Options
- Integration of Customer Specific Design & Product Features
- Observer Window
- Straight or Z-Shape
- Baby Bassinet, Coat Hooks etc.
- IFE / LCD Provisions



Wide Body Partitions & Windscreens

A330 CEO & NEO with Classic / Enhanced / Airspace Cabin
A340, A380, B767, B777



- Full Height or Underbin
- Integrated Equipment Stowages
- Wide Range of T&F Options
- Integration of Customer Specific Design & Product Features
- Customizable Outline Geometry / Shape
- Baby Bassinets, Coat Hooks, Emergency Equipment Provisions etc.
- IFE / LCD Provisions
- Airline Logo Branding





A32F Moveable Class Divider

ENH / CLASSIC Cabin

Center Header

ENH / CLASSIC Cabin

Endurance Tested for >20,000 Movement Cycles

Unique Roller & Rail Design for Unbeaten Endurance & Operation Performance

Toolless Operation

Single Person Operation & Relocation

Curtain Quick-Release



Customization Options

Retractable Movement Handle

Various Curtain Options

Various EXIT Sign Options

Curtain Quick-Release



Outboard Header

ENH / CLASSIC Cabin

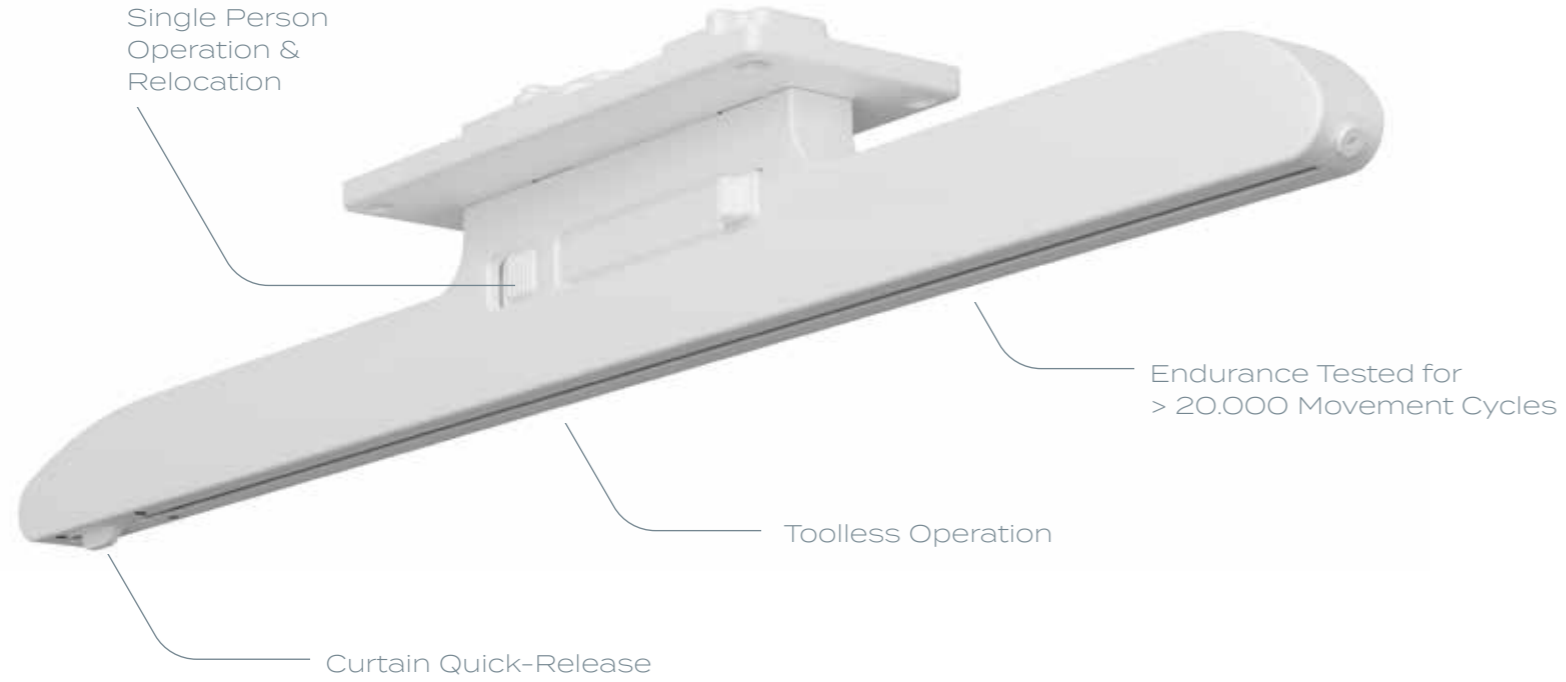

Curtain Divider

Mesh Divider

Branded Divider Panel





A32F Moveable Class Divider

Airspace Cabin

Center Curtain Header

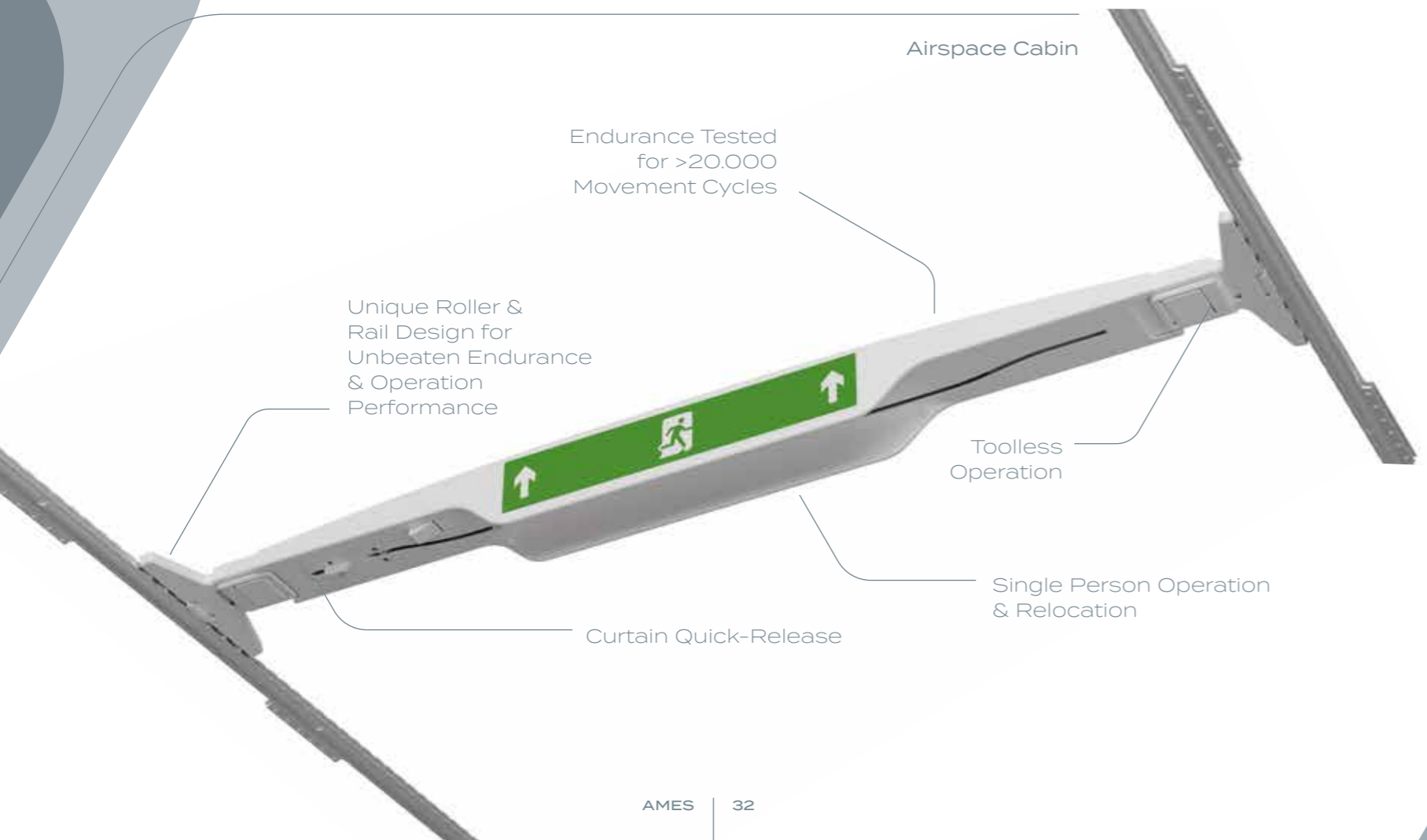

- Retractable Movement Handle
- Various Curtain Options
- Curtain Quick-Release



Outboard Header

Airspace Cabin

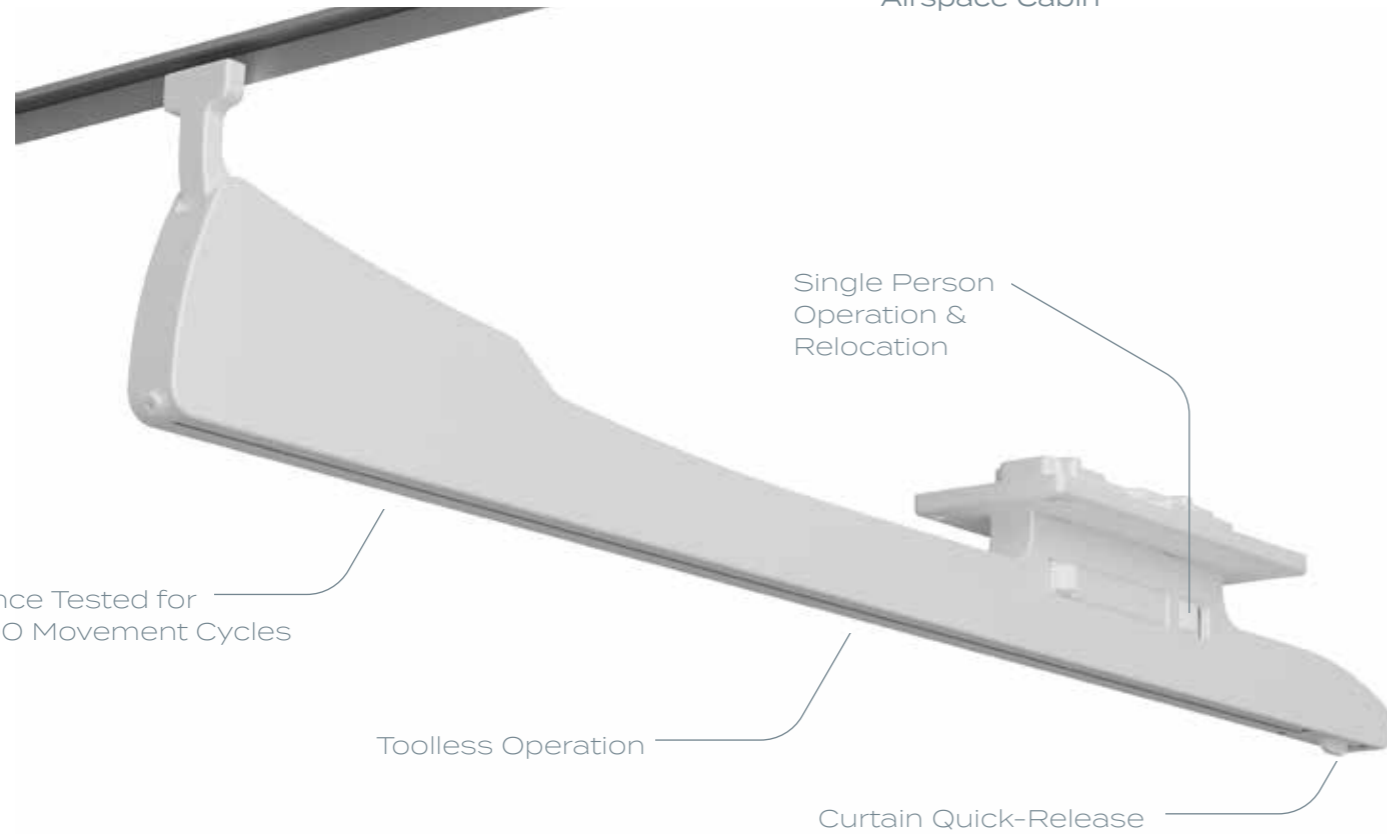

Curtain Divider

Mesh Divider

Branded Divider Panel





B737 Single-Piece
Moveable Class Divider

NG & MAX Cabin



B737 Three-Piece
Moveable Class Divider

NG & MAX Cabin



Enhance Your Cabin Product

PSU Mounted Cabin Divider

Single Aisle & Wide Body



Single Aisle

- › A32F Classic / Enhanced / Airspace Cabin
- › B737NG/MAX
- › Fully Customizable in Shape, Materials & Branding
- › Rigid Divider Panel
- › Light Weight Fabric/Mesh Dividers
- › Airline Branding Options
- › Illumination Option





Wide Body

- › A330 CEO & NEO with Classic / Enhanced / Airspace Cabin
- › A340, A380, B767, B777
- › Fully Customizable in Shape, Materials & Branding
- › Rigid Divider Panel
- › Light Weight Fabric/Mesh Dividers
- › Airline Branding Options
- › Illumination Option





Customized to your Cabin

Stowages

Single Aisle & Wide Body



Single Aisle & Wide Body Closets

- > A32F Classic / Enhanced / Airspace Cabin
- > B737NG/MAX
- > A340 / A330 CEO & NEO with Classic / Enhanced / Airspace Cabin
- > A380
- > Fully Customizable
 - > Emergency Equipment Provisions
 - > IFE / LCD Provisions





Single Aisle & Wide Body Partition Mounted Stowages

- > A32F Classic / Enhanced / Airspace Cabin
- > B737NG/MAX
- > A340 / A330 / A380
- > Fully Customizable
 - > Half-Height or Full Height Options
 - > Emergency Equipment Provisions

Single Aisle & Wide Body Floor Mounted Stowages (Doghouse)

- > A32F Classic / Enhanced / Airspace Cabin
- > B737NG/MAX
- > A340 / A330
- > B767/B777
- > Fully Customizable
 - > Emergency Equipment Provisions
 - > With Drawer or Door



Single Aisle & Wide Body Solutions

- › A330/A340
- › B767/B777
- › A320 Family
- › B737NG/MAX
- › Quick-Release Mechanism → 10min Installation/Removal
- › Customized to fit seat layout and cabin lining
- › Optional with sound absorbing curtains

10 Minutes to Install/Remove





Logos and Branding Elements

Seat Blocking Devices

- › Permanent or Temporary installation
- › Branding / Advertising options
- › Customized to fit seat geometry
- › Foldable for easy stowing



Literature Pockets



Integrated Folding Table



Equipment Stowages



Amenity Equipment

Overhead Bin Divider

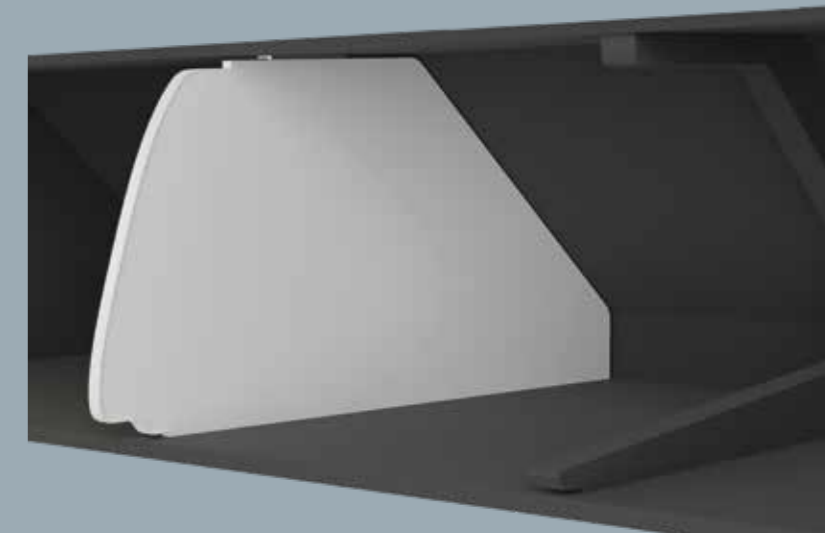



External / Livery

- > Decals & Markings
- > Registration Markings
- > Livery Application



Ownership and Registration Markings

- > Registration Plates
- > Ownership Plates
- > SELCAL Markings



Cabin Interior Placards & Markings

- > Seat Row Markers
- > Emergency Equipment Identifiers
- > EXIT Markings
- > Warning & Information Placards
- > Pictorials / Dual Language / Single Language





- > Structural Support Hardware
- > Equipment Installation Brackets & Hardware
 - > Build-to-Print Service (BTP)
 - > Build-to-Spec Service (BTS)

> Shrouds

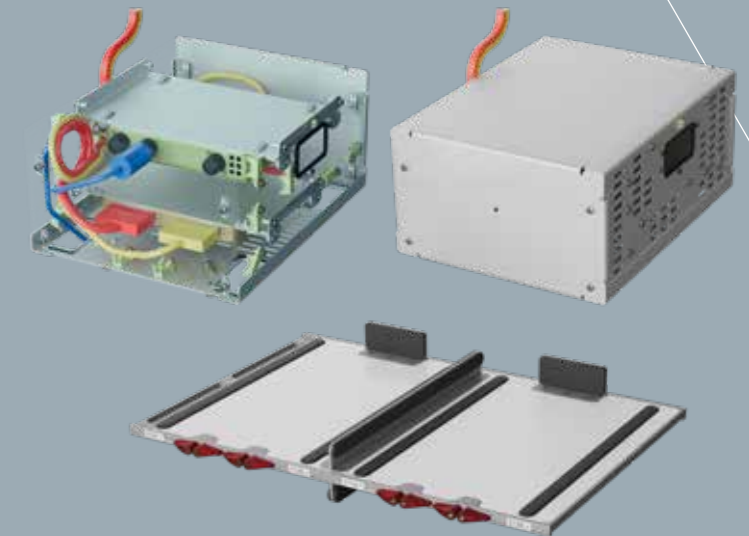

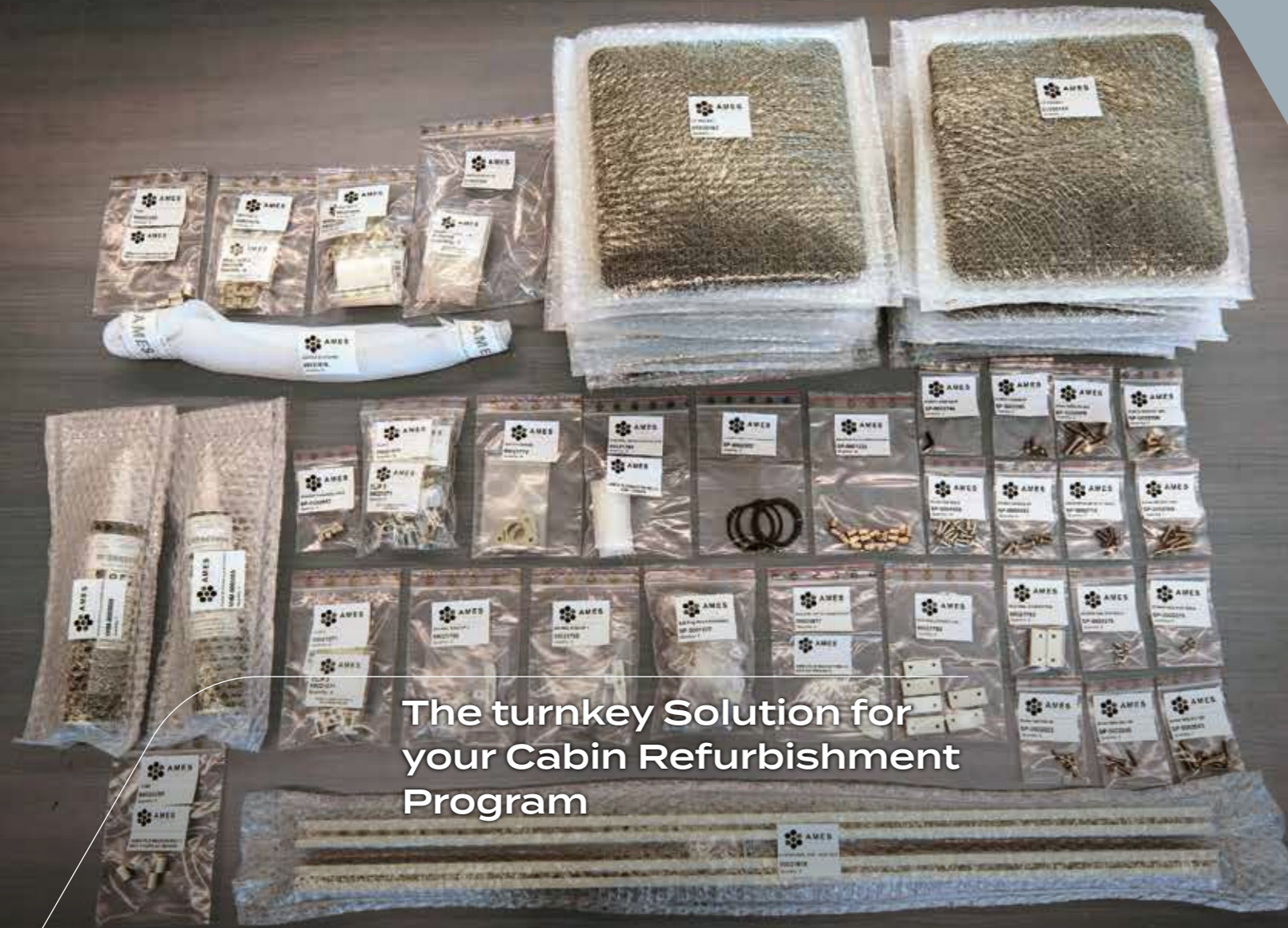

The turnkey Solution for your Cabin Refurbishment Program

- › Kitting & Logistic Services for your Modification Program
- › Sourcing of hardware and consumables, including third-party hardware
- › Packaging and kitting in line with Engineering Documentation
- › Release of installation kits with EASA Form 1
- › Logistic Support to ship installation kits to your destination - worldwide





Approved Maintenance & Repair Services since 2015

- › Maintenance, Repair and Overhaul Services for all AMES manufactured Parts and Appliances
- › Full Life Cycle Support for AMES Products

We keep our products flying longer

CAMO Services

Approved Continued Airworthiness Management Services since 2020

- › Management of Continued Airworthiness IAW PART CAMO including Subpart I Review Privilege
- › Full Aircraft Transition, Repossession and Shadow CAMO Services Available
- › EASA, Cayman, Bermudan, 2-REG Approved
 - › Other Registrations Upon Request
- › Aircraft Scope of Approval
 - › Airbus A220(BD500), A318, A319, A320, A321, A330, A350
 - › Boeing B737NG/MAX, B767, B777, B787
 - › Embraer ERJ170 / 190
 - › Other Types Upon Request
- › Numerous Aircraft Transitions on the Austrian, Bermudan, Cayman, and Maltese Register

**We take care
of your Aircraft
Asset as if it is
our own**

Consulting & Training

Our extensive industry experience for your project



Consulting & Training Services since 2011

- › Project Consulting Services in various fields of the aviation industry, including insurance, engineering, certification, lease and finance
- › Tailored Trainings to fit your needs and requirements
- › Cumulative Professional Team experience of 100+ years in different areas of international aviation
- › Benefit from the practical on-the-job experience of our AMES Group members



AMES
aerospace

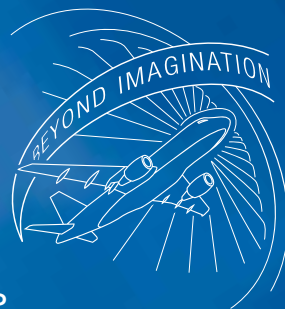

AMES GROUP

8120 Peggau, Grazerstrasse 20a | Austria
T: +43 3127 41900 E: services@ames.co.at
www.ames.aero

EASA Design Organisation **EASA.21J.299**
EASA Production Organisation **AT.21G.0015**
EASA Maintenance Organisation **AT.145.082**
EASA CAMO **IE.CAMO.123**